

Blow down valve type KAVx R1-N

Application and function

The valve is used to blow down and / or to drain steam boilers. The conception of the valve enables a fast opening necessary for the blowing down. This fast opening causes a suction in the boiler whereby deposits and possible solids are flushed out of the boiler.

Technical basic equipment

- **KAV1 R1-N** Blow-down valve with handlever.; A later equipment with pneumatic actuator is possible without problems.
- **KAV2 R1-N** Blow-down valve with pneumatic actuator for automatic blowing down in connection with the program-controlled IGEMA magnetic valve type PGM
- Construction as globe valve with flange connection or welding end according to DIN
- Quick closing mechanism for fast closing and opening
- Adjustable stuffing box
- Clamp-in valve seat
- Possibility to lock the valve manually in open position
- Possibility to operate the pneumatic actuator with the control media air or water

Materials: pressure holding parts: steel for high-temperature service
 Spindle, seat and cone: stainless steel
 Yoke: carbon steel
 Lever: carbon steel

Available (optional) versions

- Other process connections as per DIN or ANSI on request

Technical data

Allowable pressure	PS [bar]	32	50
Allowable temperature	TS [° C]	239	265

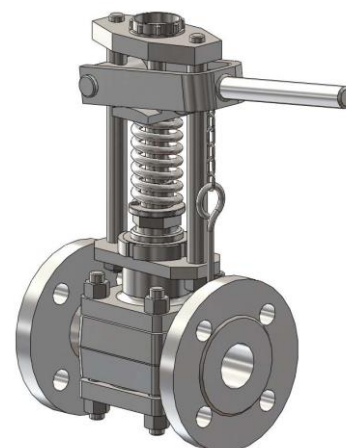

KAV1 R1-N

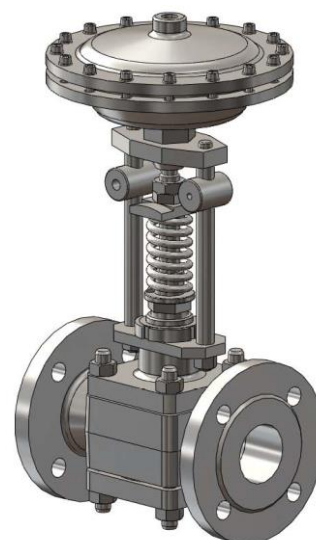

KAV2 R1-N

Dimensions

Version with flange				
PS [bar]	Connecton flange D	Contact face	Dimension L [mm]	
32	DN 20 DIN 2635	DIN 2626-C	160	
	DN 25 DIN 2635		160	
	DN 32 DIN 2635		180	
	DN 40 DIN 2635		200	
	DN 50 DIN 2635		230	
50	DN 25 DIN 2637	DIN 2526-E	190	
	DN 40 DIN 2637		220	
Version with welding end as per DIN 3239-2				
PS [bar]	DN	ø dp [mm]	ø d2 [mm]	Dimension L [mm]
32	20	22	28	160
	25	28,5	34	160
	40	43	49	210
50	25	28,5	34	160
	40	42	61	210

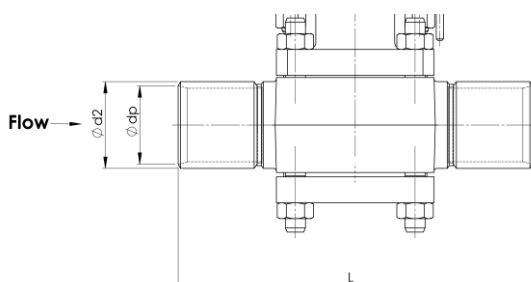
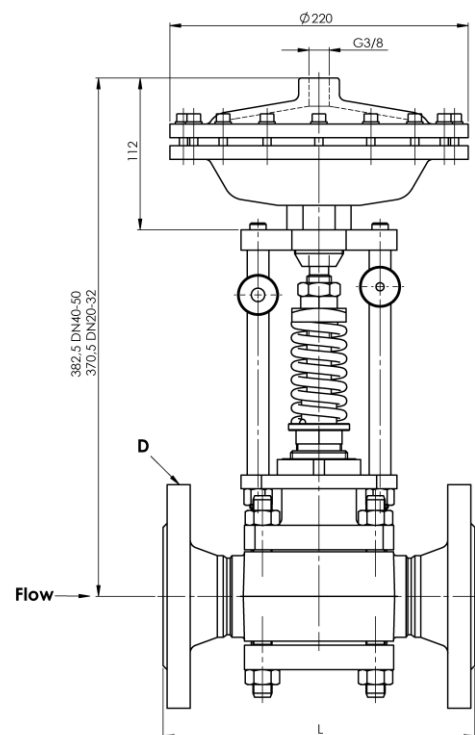
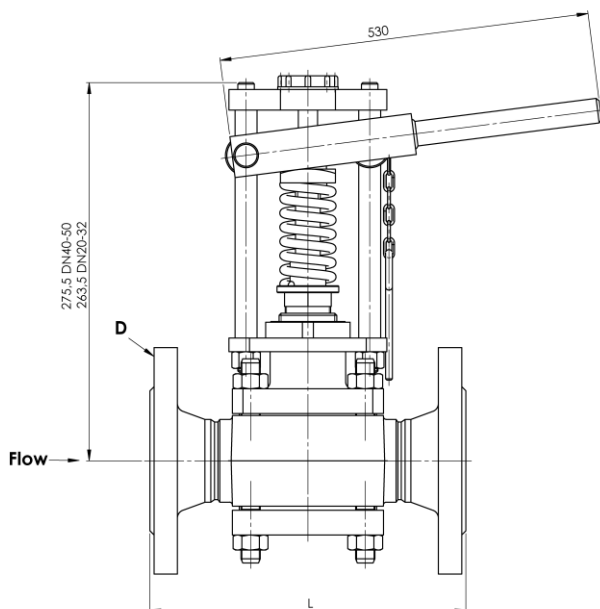

Pneumatic actuator, required control pressure:

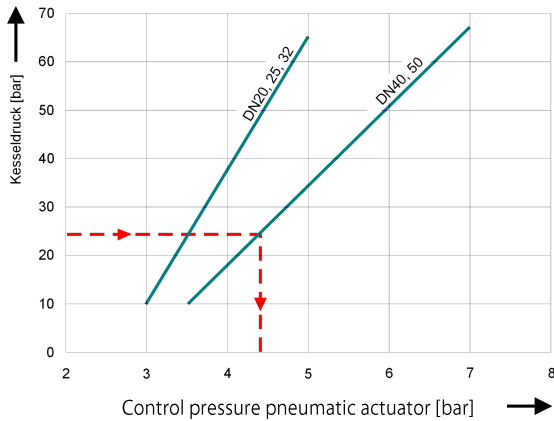

Reading example:

Boiler pressure: 25 bar
Nominal diameter of valve: DN40

Result: Control pressure 4,3 bar

The determined control pressure may be exceeded by max. 10%.

Hint:

Filling volume of pneumatic actuator per blowing down process: 0,55 l. The pneumatic actuator may only be operated with a control pressure of **max. 7 bar** to exclude a destruction of the pneumatic actuator or the diaphragm.

Material:

Case	cast aluminium
Spindle	stainless steel
Diaphragm	rubber



Position of the handle: in flow direction (see drawing). Other positions of the lever (turned by 90°) must be fixed in case of order.

Standard values for frequency and duration of blowing down: see Operating Instructions

Installation example

